

MANIFOLDS		
DESCRIPTION	MODEL SERIES	PAGE NO.
MANIFOLD	MD03	4
MANIFOLD	MD05	5
MANIFOLD - PARALLEL CIRCUIT	MD08	6
MANIFOLD - SERIES CIRCUIT	MD08	7
SUBPLATES		
DESCRIPTION	MODEL SERIES	PAGE NO.
SUBPLATES - SIDE AND BOTTOM PORTED (CAST IRON)	SD03	8
SUBPLATES - WITH OR WITHOUT RELIEF CAVITY	SD03	9
SUBPLATES - SIDE AND BOTTOM PORTED (CAST IRON)	SD05	10
SUBPLATES - WITH OR WITHOUT RELIEF CAVITY	SD05	11
SUBPLATES - SIDE PORTED (CAST IRON)	SD08	12
SUBPLATES - BOTTOM PORTED (CAST IRON)	SD08	13
SUBPLATES (CAST IRON)	SD10	14
SUBPLATES (CAST IRON)	S2F06 & SP08	15
MULTIPLE VALVE MANIFOLD ACCESSORIES		
DESCRIPTION	MODEL SERIES	PAGE NO.
COVER PLATES	MC03	16
COVER PLATES	MC05	17
COVER PLATES	MC08	18
TRANSITION PLATES	MA05, MA07	19
TRANSITION PLATES	MA05, MA08	20
TRANSITION PLATES	MA03, MA08	21
TAPPING PLATES	MT03, MT05	22
MANIFOLD PLUGS	PD03, PD05	23
MOUNTING FLANGES	MF03, MF05	23
FOOT BRACKETS	FD03, FD05, FD08	23
VALVE BOLT/STUD KITS		
DESCRIPTION	MODEL SERIES	PAGE NO.
STACK VALVES	ALL MODELS	24
MOUNTING SURFACES		
SIZE NFPA	PAGE NO.	
D03, D05	25	
D08, D10	26	
2FO6, P08	27	

INTEGRATED CIRCUIT MANIFOLDS TO MATCH YOUR FLUID POWER NEEDS

FEATURES & BENEFITS

Increase cycle time, reduce component and machine size, minimize space requirements, eliminate potential leaks, reduce piping, increase pressure -- these are the typical needs of fluid power systems.

Integrated circuit manifolds save 30-70% in labor and material costs by eliminating intervalve piping and providing for consistent circuit every time.

CONTINENTAL HYDRAULICS, with its new high-speed machining capabilities, can now produce **INTEGRATED CIRCUIT MANIFOLDS** to match your fluid power needs.

We can quote and produce from your already completed machine drawings. Or we can quote and produce directly from your designed hydraulic schematic, along with specified flow and pressure requirements for each component required in the circuit.

CONTINENTAL HYDRAULICS can supply **INTEGRATED CIRCUIT MANIFOLDS** to include Sun Hydraulic cartridges. Or we can produce and ship manifolds to match other cartridge valve manufacturers such as Hydraforce, Delta, Deltrol, Compact Controls and Modular Controls. All you need to do is identify by model code how you want the manifold produced and with what valves.

The customer/distributor supplies the design as shown by the following example, including a schematic, bill of material, flow and pressure required, port sizes, special block material (if other than aluminum), and any other pertinent information.

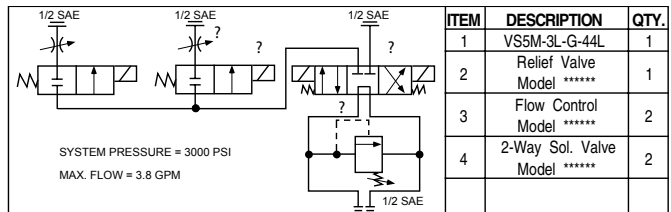

QUOTING:

CHD will take the above design and quote an **INTEGRATED CIRCUIT MANIFOLD** based on your specifications supplied without components, or supplied with components from **CONTINENTAL HYDRAULICS**. If you have specific dimensional parameters, please specify them because a preliminary engineering layout may be required.

Quote time is about one week. Delivery in small production quantities will be four to six weeks for the manifold only (does not include cartridge valves) and is subject to prior sales.

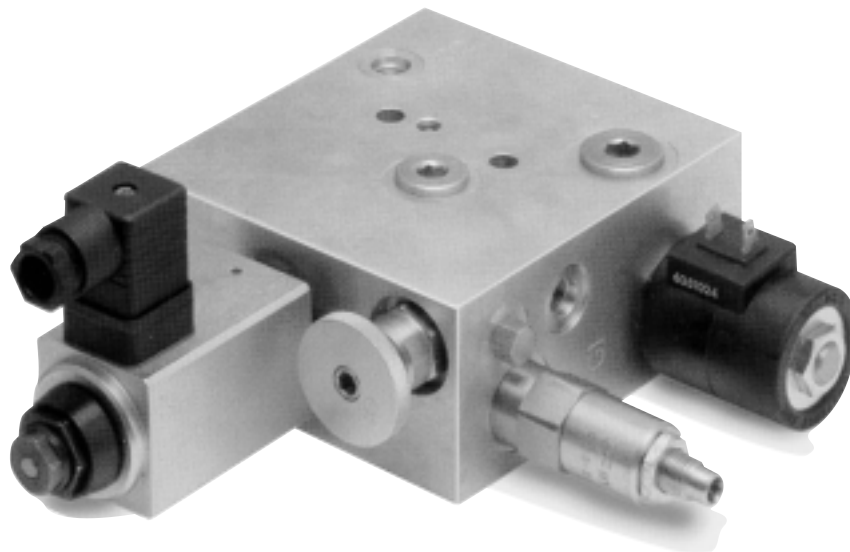

INTEGRATED CIRCUIT MANIFOLDS

INTEGRATED CIRCUIT MANIFOLDS (Continued)



ENGINEERING

Once we have received your quoted order, Engineering uses CAD/CAM software (with 3D solid modeling capabilities) to complete the design, release the design to manufacturing and produce it to your specifications.

Specifically engineered to offer a unique product or system that is designed for the OEM customer's specific machine or application.

MANUFACTURING

CONTINENTAL HYDRAULICS has the capacity to produce large quantities very quickly using new, state-of-the-art, high-speed CNC machining centers with multiple workstations for fast set-up, multi-part runs and quick turn-around.

The integrated block design is translated to a machining program through our CAMAX software and downloaded directly to the machine for completing the production of the final part.

Capabilities of production quantities from small prototypes to large production from quantities in the 100's or 1,000's.



MULTIPLE VALVE MANIFOLDS

NFPA SIZE: D03 (FORMERLY D01)

3000 PSI PRESSURE RATED

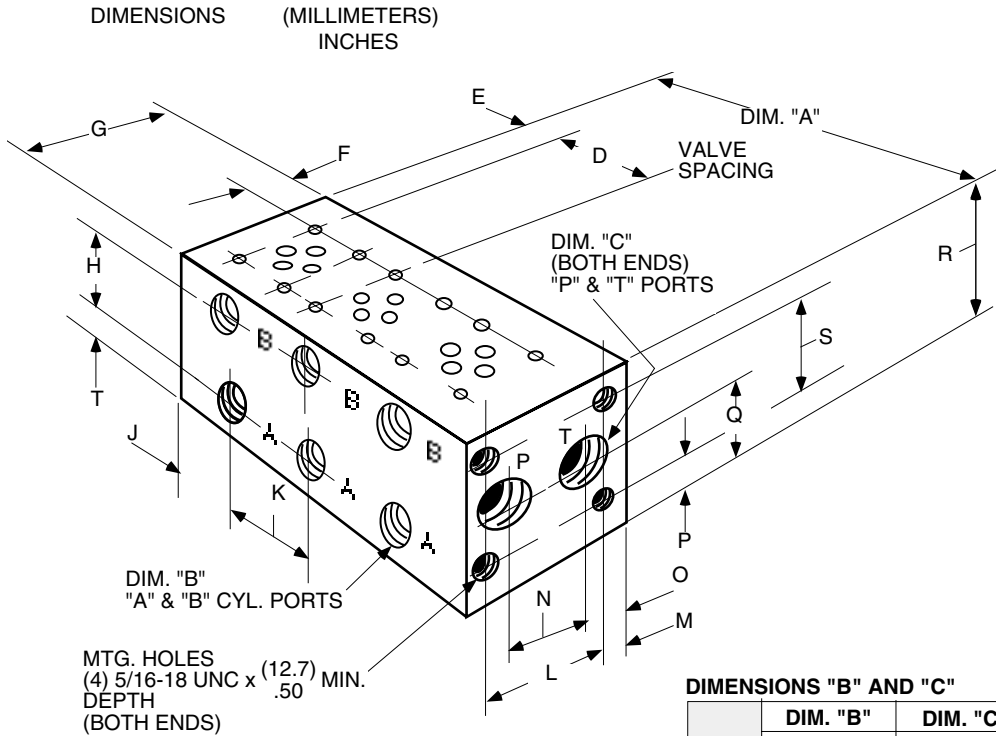

DIMENSIONS "D" THROUGH "T"

DIM.	D03
D	(54.0) 2.13
E	(23.1) .91
F	(16.5) .65
G	(76.2) 3.00
H	(44.5) 1.75
I	(15.0) .59
J	(38.6) 1.52
K	(54.0) 2.13
L	(60.4) 2.38
M	(7.9) .31
N	(38.1) 1.50
O	(19.1) .75
P	(7.9) .31
Q	(38.1) 1.50
R	(74.7) 2.94
S	(58.9) 2.32
T	(15.0) .59

DIMENSIONS "B" AND "C"

CODE	DIM. "B"	DIM. "C"
	"A" & "B" CYL. PORTS	"P" & "T" PORTS
38	3/8" NPTF	1/2" NPTF
08	#8 SAE 3/4 - 16 UNF	#10 SAE 7/8 - 14 UNF

DIMENSION "A"

NO. OF STATIONS	1	2	3	4	5	6	7	8	9	10
NFPA SIZE D03	(83.8) 3.30	(131.3) 5.17	(185.4) 7.30	(239.5) 9.43	(293.6) 11.56	(347.7) 13.69	(401.8) 15.82	(455.9) 17.95	(510.0) 20.08	(564.1) 22.21

ORDERING INFORMATION

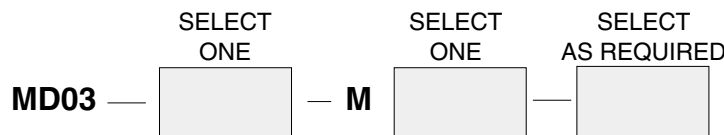

NOTES:

- A = A CYLINDER PORT
- B = B CYLINDER PORT
- P = PRESSURE PORT
- T = TANK PORT

CODE	PORT SIZE
08	SEE ABOVE
38	SEE ABOVE

NOTES:

- ? ON SERIES CIRCUIT, MANIFOLDS (1) "P" & (1) "T" PORTS ARE PLUGGED.
- ? SERIES CIRCUIT AVAILABLE ONLY IN 2 THROUGH 5 STATIONS.

NO. OF STATIONS		WEIGHT lbs. (kg.)
CODE	DESCRIPTION	
1	FOR 1 VALVE	2.0 (.91)
2	FOR 2 VALVES	4.8 (2.2)
3	FOR 3 VALVES	6.3 (2.9)
4	FOR 4 VALVES	8.0 (3.6)
5	FOR 5 VALVES	9.5 (4.3)
6	FOR 6 VALVES	11.5 (5.2)
7	FOR 7 VALVES	13.0 (5.9)
8	FOR 8 VALVES	15.0 (6.8)
9	FOR 9 VALVES	17.0 (7.7)
10	FOR 10 VALVES	19.0 (8.6)

MECHANICAL OPTIONS	
CODE	DESCRIPTION
OMIT	STD. 2.13" SPACING
P	PARALLEL CIRCUIT
S	SERIES CIRCUIT ??
R1 *	MODULAR CONTROLS CAVITY C-10-2
R2	SUN RELIEF CAVITY T-10A
F **	ADDITIONAL "P" & "T" PORTS ON "P" TO "T" AT FIRST STATION
SI	THROUGH MOUNTING HOLES

* NOT AVAILABLE FOR SINGLE STATION.
** CODE 38 ONLY.

NFPA D05 MULTIPLE VALVE MANIFOLDS

NFPA D05 SIZE (FORMERLY D02)

3000 PSI PRESSURE RATED

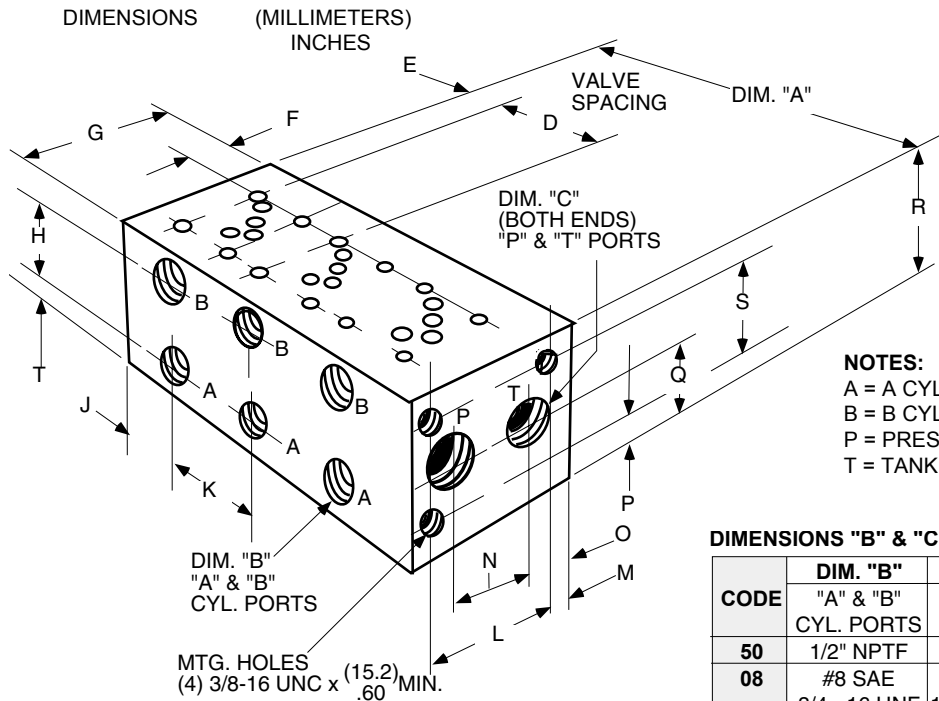

DIMENSIONS "D" THROUGH "T"

DIM.	D05
D	(82.6) 3.25
E	(22.1) .87
F	(31.0) 1.22
G	(95.2) 3.75
H	(50.8) 2.00
I	(19.1) .75
J	(46.7) 1.84
K	(82.6) 3.25
L	(69.8) 2.75
M	(12.7) .50
N	(44.5) 1.75
O	(25.4) 1.00
P	(9.4) .37
Q	(44.5) 1.75
R	(87.4) 3.44
S	(69.9) 2.75
T	(19.1) .75

NOTES:
A = A CYLINDER PORT
B = B CYLINDER PORT
P = PRESSURE PORT
T = TANK PORT

DIMENSIONS "B" & "C"

CODE	DIM. "B" "A" & "B" CYL. PORTS	DIM. "C" "P" & "T" PORTS
50	1/2" NPTF	3/4" NPTF
08	#8 SAE 3/4 - 16 UNF	#12 SAE 1-1/16-12 UNF

DIMENSION "A"

NO. OF STATIONS	1	2	3	4	5	6	7	8
NFPA SIZE D05	(90.4) 3.56	(1730) 6.81	(255.5) 10.08	(338.1) 13.31	(420.6) 16.56	(503.2) 19.81	(585.7) 23.06	(668.3) 26.31
CODE W D05	N/A	(217.4) 8.56	(344.4) 13.56	(471.4) 18.56	(598.4) 23.56	(725.4) 28.56	(852.4) 33.56	(979.4) 38.56

N/A = NOT AVAILABLE

ORDERING INFORMATION

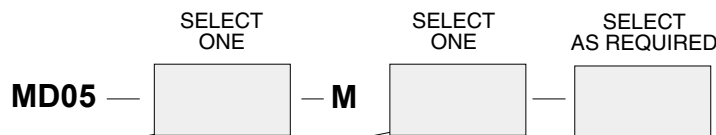

CODE	PORT SIZE
08	SEE ABOVE
50	SEE ABOVE

CODE	DESCRIPTION	WEIGHT lbs. (kg.)	
		STD. SPACE	WIDE SPACE
1	FOR 1 VALVE	4.0 (1.8)	----
2	FOR 2 VALVES	7.5 (3.4)	9.0 (4.1)
3	FOR 3 VALVES	10.5 (4.8)	16.0 (7.2)
4	FOR 4 VALVES	13.5 (6.1)	20.0 (9.0)
5	FOR 5 VALVES	17.0 (7.7)	25.0 (11.3)
6	FOR 6 VALVES	20.0 (9.1)	31.0 (14.0)
7	FOR 7 VALVES	23.5 (10.7)	37.0 (16.7)
8	FOR 8 VALVES	26.5 (12.0)	43.0 (19.5)

MECHANICAL OPTIONS	
CODE	DESCRIPTION
OMIT	STD. 3.25" SPACING
W	WIDE 5.00" SPACING ? ⁵
P	PARALLEL CIRCUIT
S	SERIES CIRCUIT ??
R1 *	MODULAR CONTROLS CAVITY C-10-2 ?
R2	SUN RELIEF CAVITY T-10A ?
F	ADDITIONAL "P" TO "T" PORTS ON MANIFOLD BOTTOM AT FIRST STATION
CC	OPTIONAL MOUNTING OF CHECK IN P, T, A OR B PORT (CONSULT FACTORY) ?
S1	THROUGH MOUNTING HOLES

- NOTES:**
1. PORTS ARE PLUGGED ON SERIES CIRCUIT MANIFOLDS (1) "P" & (1) "T".
 2. STD. SERIES MANIFOLDS AVAILABLE ONLY 2 THROUGH 7 STATION.
 3. WIDE SERIES MANIFOLDS AVAILABLE ONLY 2 THROUGH 5 STATION.
 4. CODES C, R1, R2 OR F ONLY AVAILABLE IN PARALLEL CIRCUIT.
 5. DIMENSION "D" & "K": ADD 1.75 " (44.4 MM).

* NOT AVAILABLE FOR SINGLE STATION.

NFPA D08 SIZE (FORMERLY D06)
SERIES CIRCUIT ALUMINUM
MULTIPLE VALVE MANIFOLDS

3000 PSI PRESSURE RATED

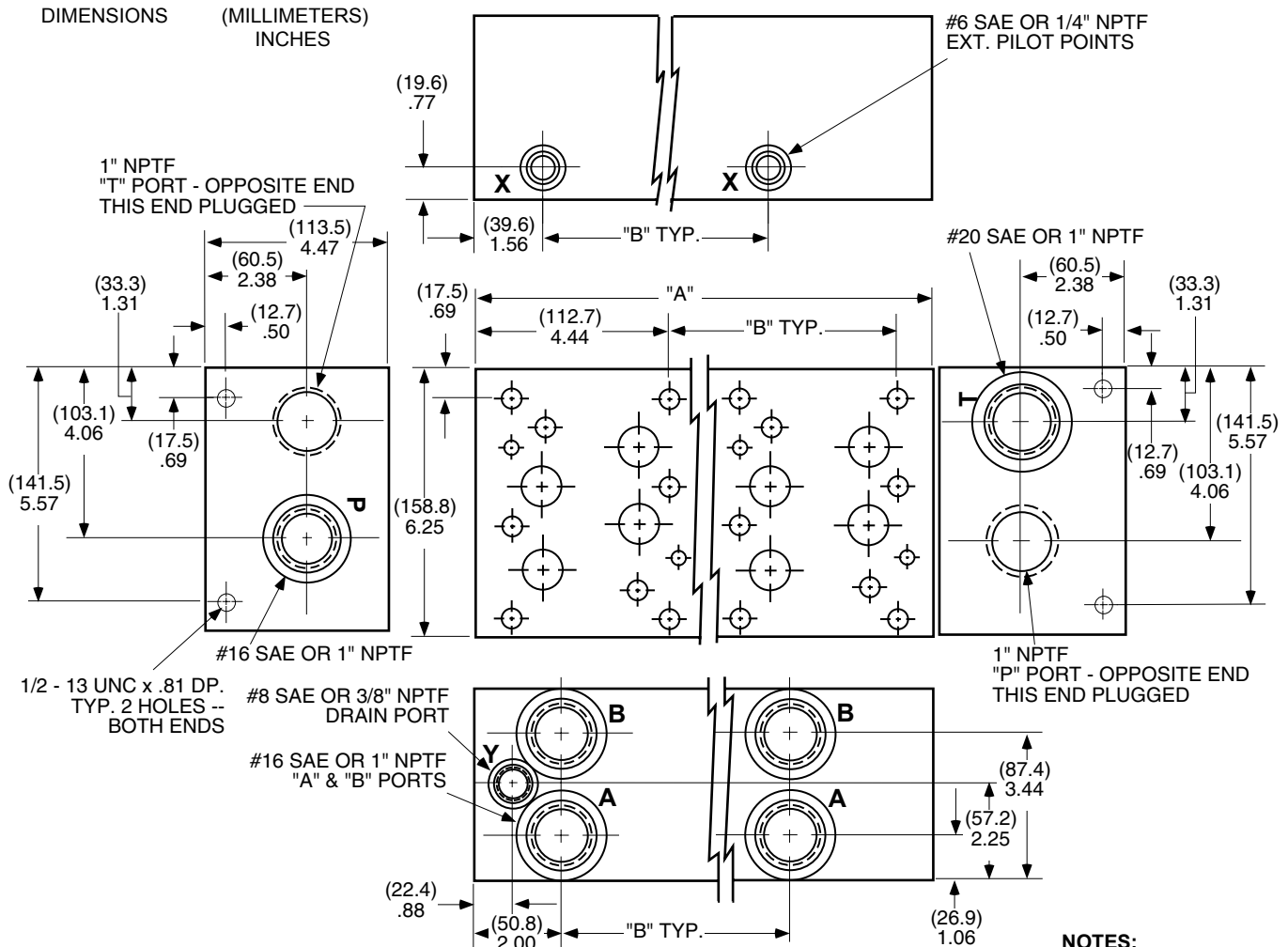

DIMENSION "A" INFORMATION

NO. OF STATIONS	2	3	4
"B" = (133.4) STD. SPACE	(266.7)	(400.0)	(533.4)
5.25 SPACE	10.50	15.75	21.00
"B" = (177.8) WIDE SPACE	(311.2)	(489.0)	(666.8)
7.00 SPACE	12.25	19.25	26.25

NOTES:

- A = A CYLINDER PORT
- B = B CYLINDER PORT
- P = PRESSURE PORT
- T = TANK PORT
- X = PILOT PORT
- Y = DRAIN PORT

ORDERING INFORMATION

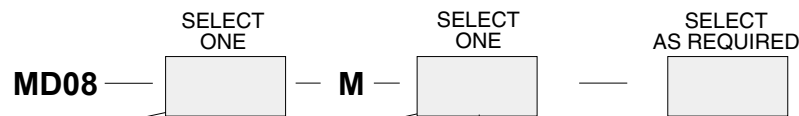

CODE	PORT SIZE
16	#16 & #20 SAE
100	1" NPTF

NO. OF STATIONS	
CODE	DESCRIPTION
2	FOR 2 VALVES
3	FOR 3 VALVES
4	FOR 4 VALVES

WEIGHT lbs. (kg)	
STD. SPACE	WIDE SPACE
23.0 (10.4)	27.0 (12.2)
34.0 (15.4)	43.0 (19.5)
46.0 (20.9)	59.0 (26.7)

MECHANICAL OPTIONS	
CODE	DESCRIPTION
S	SERIES CIRCUIT

NOTES:

1. ALL PORTS SAE OR NPTF CONSISTENT WITH PORTS ORDERED.
2. SERIES AVAILABLE 2 THROUGH 4 STATION ONLY.

NFPA SIZE: D03 (FORMERLY D01)

5000 PSI PRESSURE RATED

DIMENSIONS (MILLIMETERS)
 INCHES

NOTES:
 A = A CYLINDER PORT
 B = B CYLINDER PORT
 P = PRESSURE PORT
 T = TANK PORT

SIDE PORTED

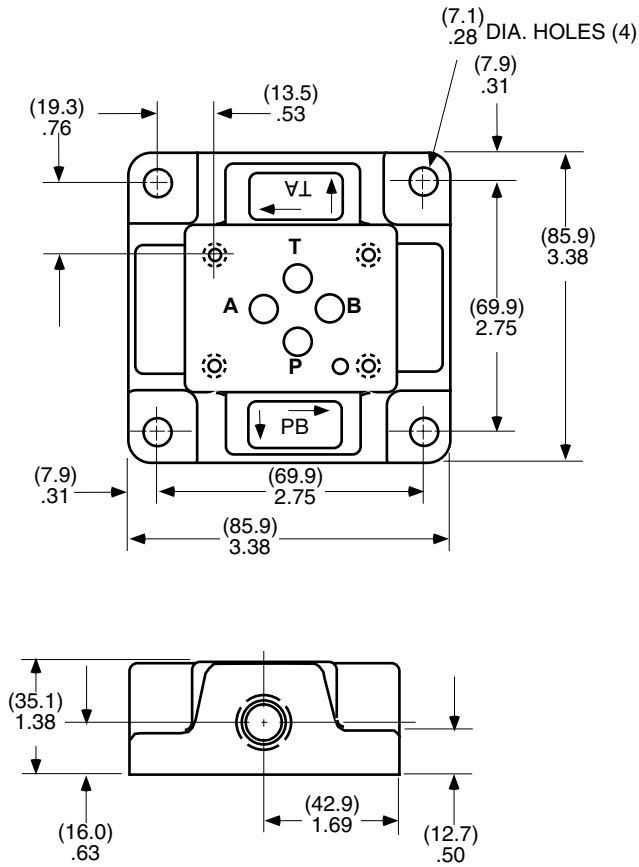

BOTTOM PORTED

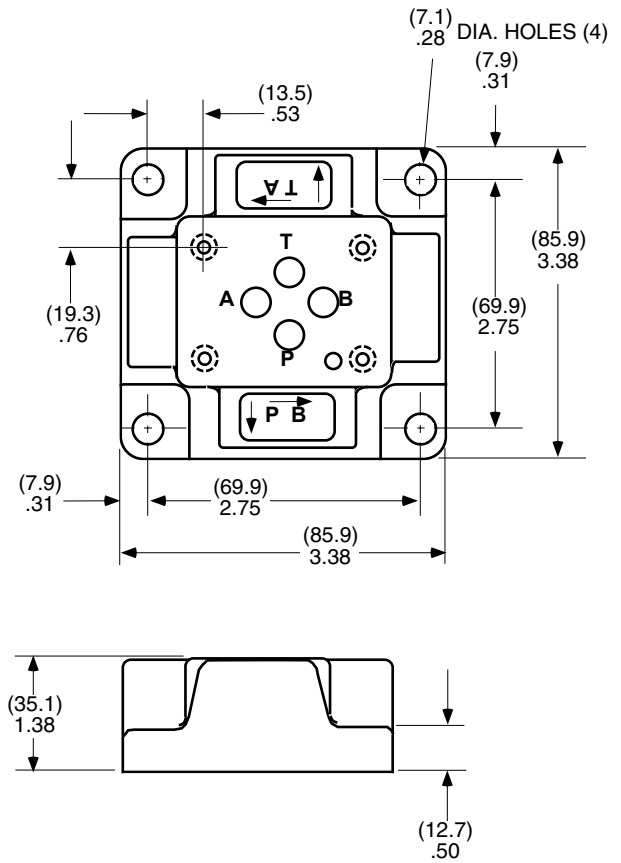

ORDERING INFORMATION

SD03-C

SELECT ONE

SELECT ONE

CODE	PORT SIZE
06	#6 SAE
08	#8 SAE
25	1/4" NPTF
38	3/8" NPTF

CODE	PORT SIZE
S	SIDE
B	BOTTOM

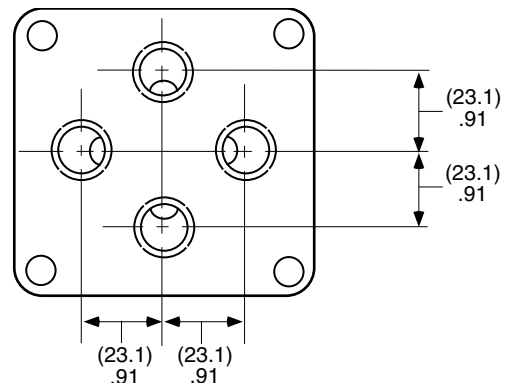

WEIGHT: 3 lbs (1.4 kg.) CAST IRON

NFPA D03 SUBPLATES

NFPA SIZE: D03 (FORMERLY D01)
WITH OPTIONAL RELIEF VALVE CAVITY

3000 PSI PRESSURE RATED

DIMENSIONS (MILLIMETERS)
 INCHES

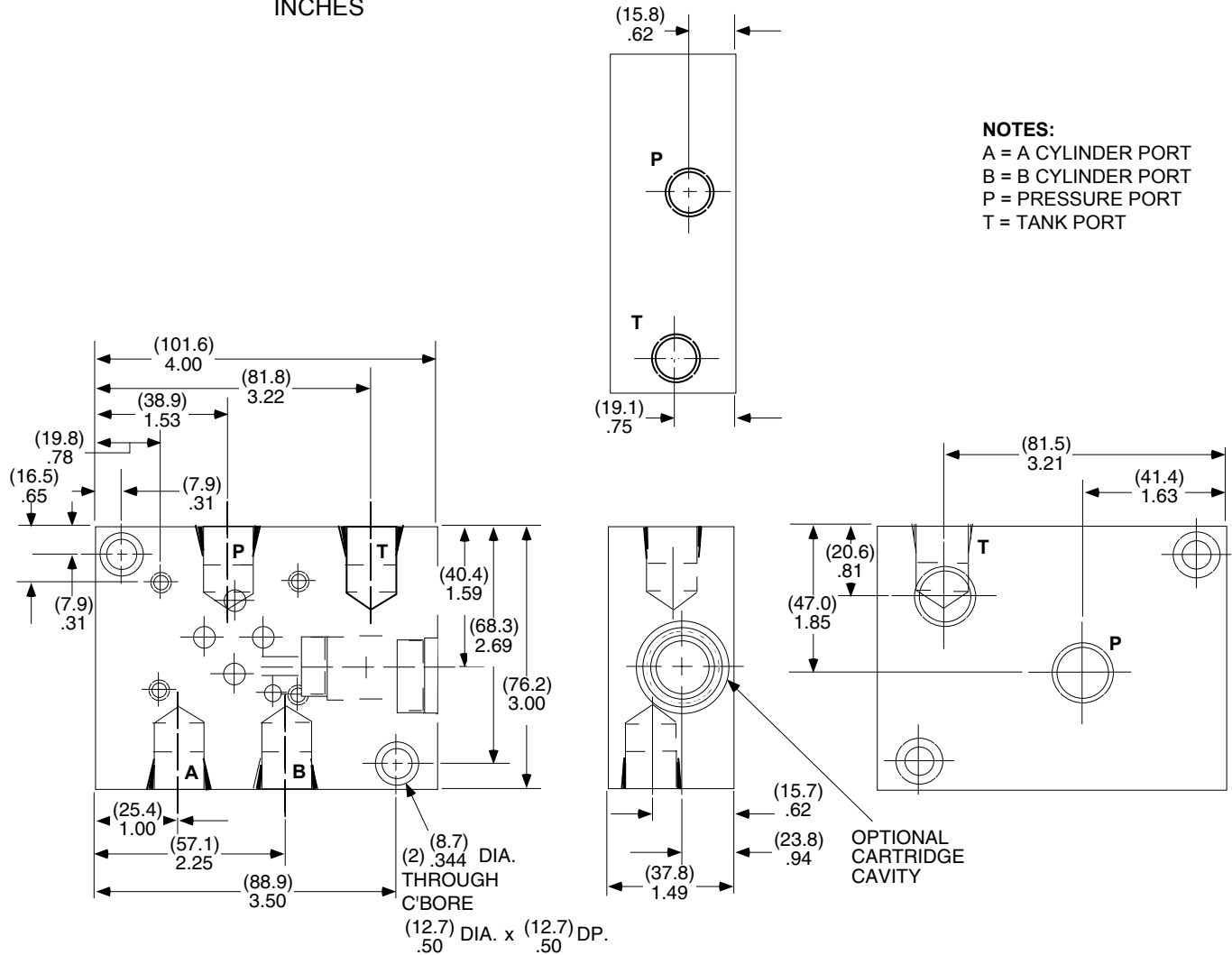

ORDERING INFORMATION

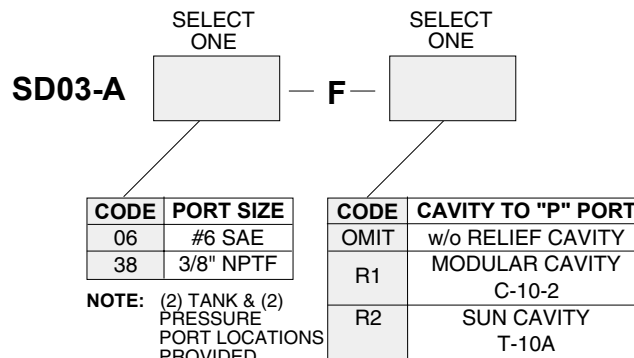

WEIGHT: 2.0 lbs (91 kg.) ALUMINUM

NFPA SIZE: D05 (FORMERLY D02)

DIMENSIONS (MILLIMETERS)
 INCHES

BOTTOM PORTED

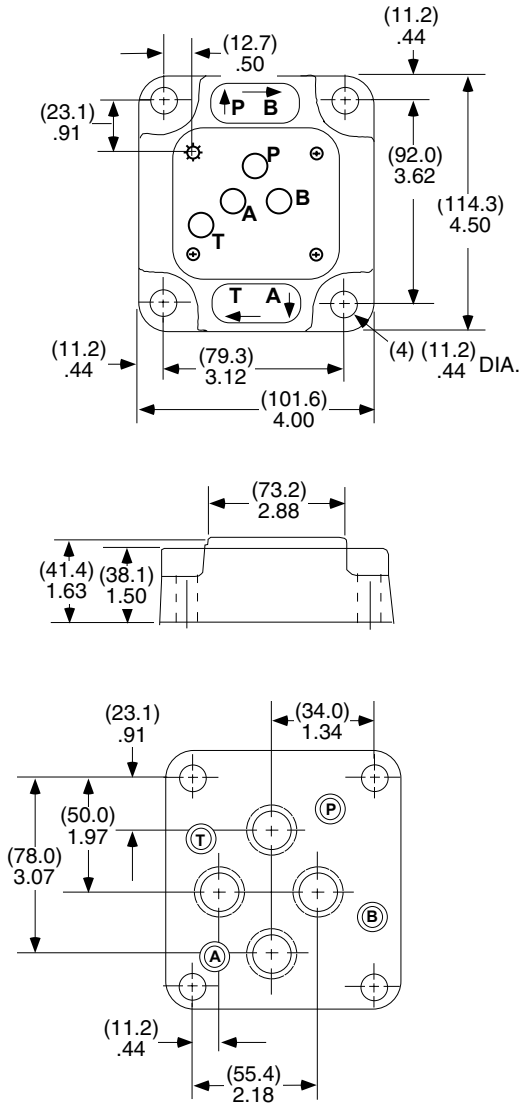

SIDE PORTED

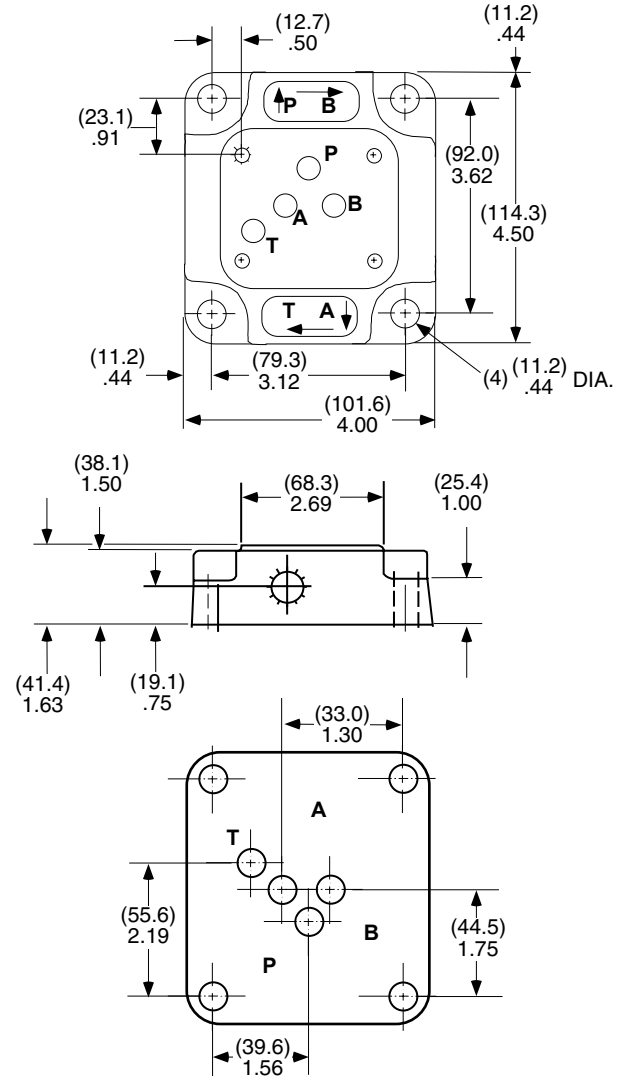

5000 PSI PRESSURE RATED

NOTES:
 A = A CYLINDER PORT
 B = B CYLINDER PORT
 P = PRESSURE PORT
 T = TANK PORT

ORDERING INFORMATION

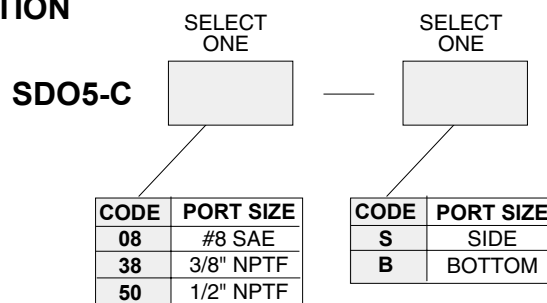

WEIGHT: 6 lbs. (92.7 kg.) CAST IRON

NFPA D05 SUBPLATES

NFPA SIZE: D05 (FORMERLY D02)
WITH OPTIONAL RELIEF CAVITY

3000 PSI PRESSURE RATED

DIMENSIONS (MILLIMETERS)
 INCHES

NOTES:

A = A CYLINDER PORT
 B = B CYLINDER PORT
 P = PRESSURE PORT
 T = TANK PORT

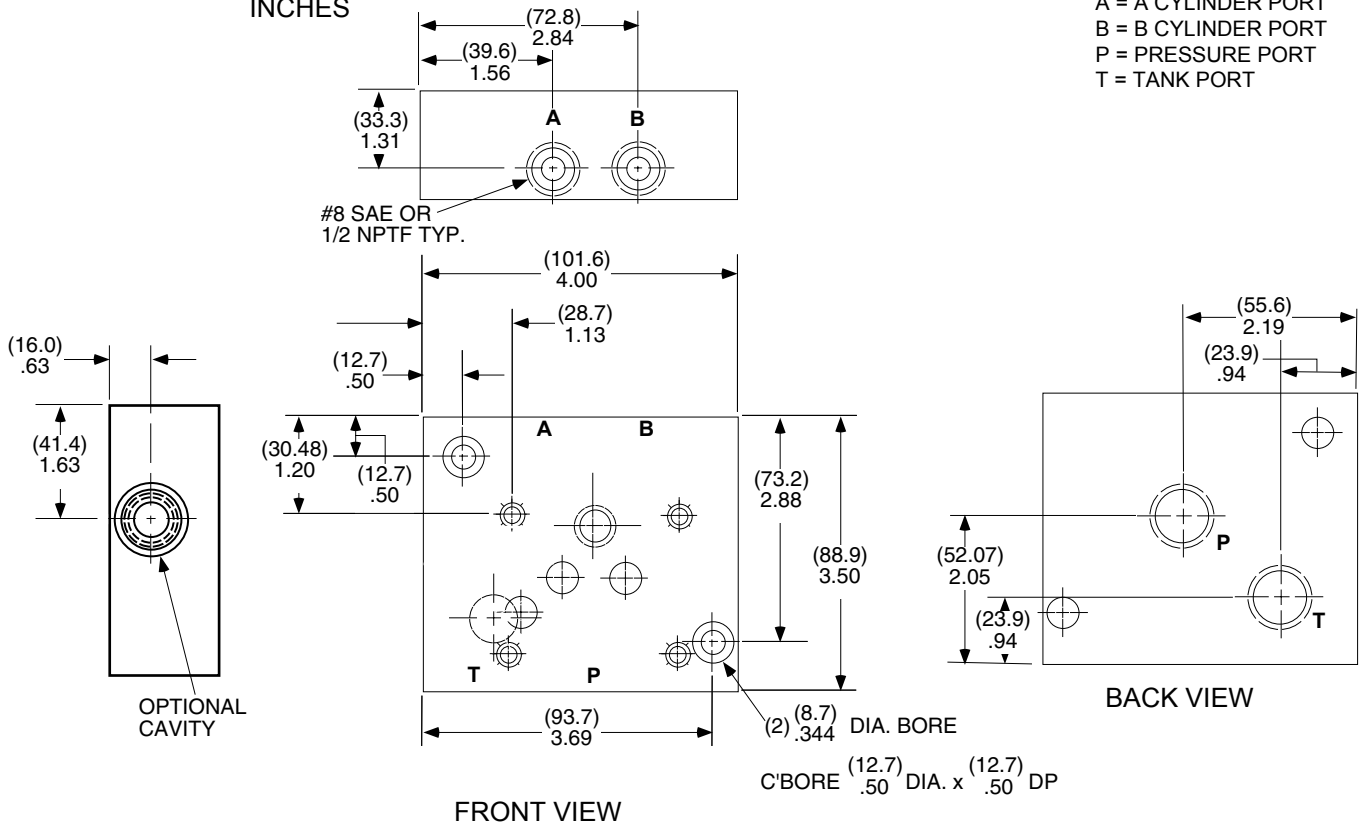

ORDERING INFORMATION

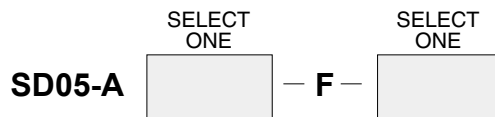

CODE	PORT SIZE
08	#8 SAE
50	1/2" NPTF

CODE	CAVITY TO "P" PORT
OMIT	w/o RELIEF CAVITY
R1	MODULAR CAVITY C-10-2
R2	SUN CAVITY T-10A

NOTES:
 1. (2) TANK &
 (2) PRESSURE
 PORT LOCATIONS
 PROVIDED.

WEIGHT: 3.0 lbs. (1.36 kg.) ALUMINUM

NFPA SIZE: D08 (FORMERLY D06)

5000 PSI PRESSURE RATED
 EXCEPT CODE 20 RATED AT 3000 PSI

NOTES:
 A = A CYLINDER PORT
 B = B CYLINDER PORT
 P = PRESSURE PORT
 T = TANK PORT
 Y = DRAIN PORT
 X = PILOT PORT

DIMENSIONS (MILLIMETERS)
 INCHES

SIDE PORTED
CODE 20

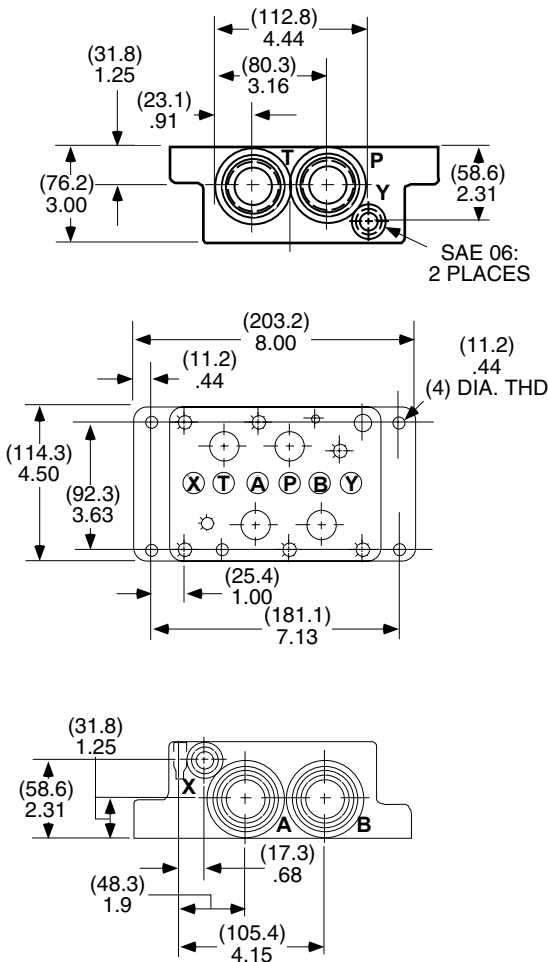

SIDE PORTED
CODES 12, 16, 75 & 100

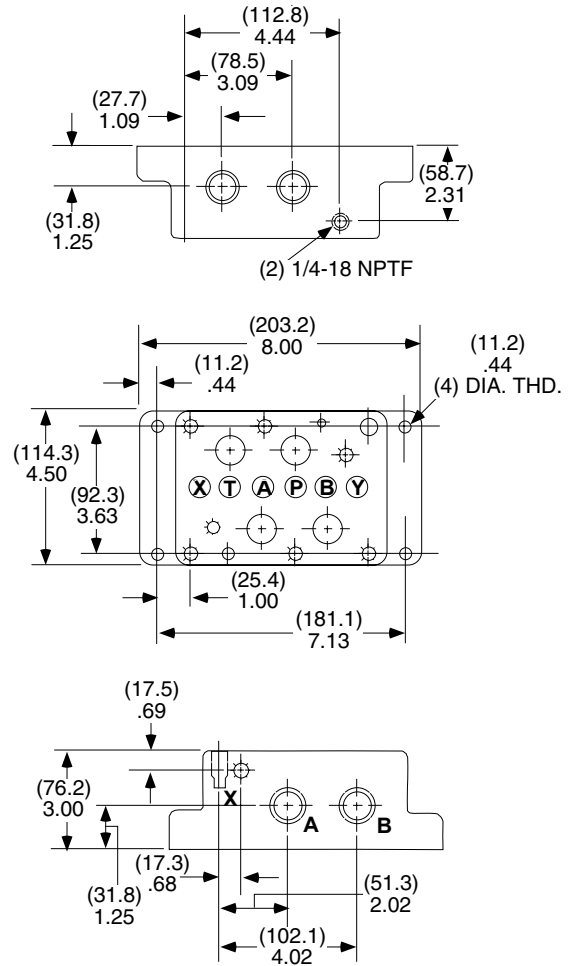

ORDERING INFORMATION

SELECT ONE
 SD08-C — S

CODE	PORT SIZE	PRESS. RATING
12	#12 SAE	5000 PSI
16	#16 SAE	5000 PSI
20	#20 SAE	3000 PSI
75	3/4" NPTF	5000 PSI
100	1" NPTF	5000 PSI

WEIGHT: 22.4 lbs. (10.2 kg.) CAST IRON

NFPA D08 BOTTOM PORT SUBPLATES



NFPA SIZE: D08 (Formerly D06)

**DIMENSIONS (MILLIMETERS)
INCHES**

NOTES:

- A = A CYLINDER PORT
- B = B CYLINDER PORT
- P = PRESSURE PORT
- T = TANK PORT
- X = PILOT PORT
- Y = DRAIN PORT

5000 PSI RATED PRESSURE EXCEPT:
3500 PSI RATED PRESSURE CODES 12 & 16
3000 PSI RATED PRESSURE CODES 20 & 125

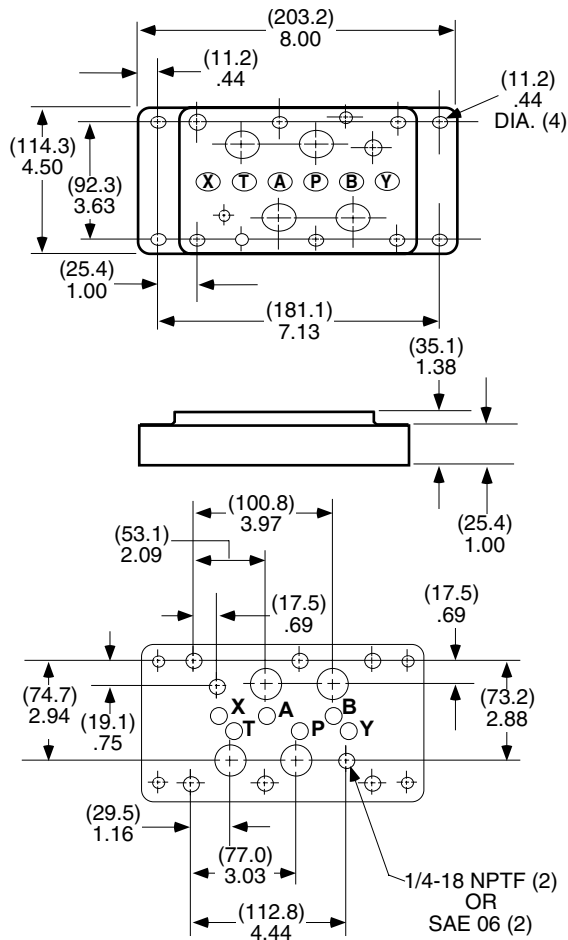

**BOTTOM PORTED
CODE 20, 125**

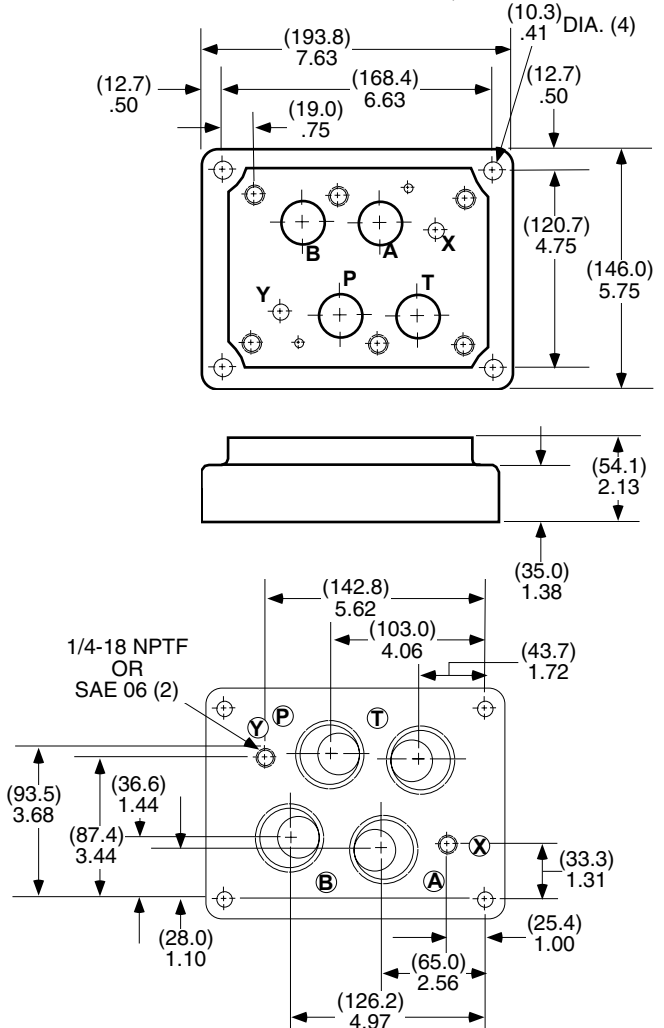

ORDERING INFORMATION

SELECT ONE
SD08 — C **B**

CODE	PORT SIZE	PRESS. RATING
12	#12 SAE	5000 PSI
16	#16 SAE	3500 PSI
20	#20 SAE	3000 PSI
75	3/4" NPTF	5000 PSI
100	1" NPTF	3500 PSI
125	1-1/4" NPTF	3000 PSI

NOTES:

1. SAE or NPTF "X" & "Y" PORTS PROVIDE CONSISTENT WITH PORT OPTION ORDERED.

WEIGHT: 10.2 lbs. (4.6 kg.) CAST IRON

NFPA SIZE: D10 (FORMERLY D06)

3000 PSI RATED PRESSURE

DIMENSIONS (MILLIMETERS)
 INCHES

NOTES:

- A = A CYLINDER PORT
- B = B CYLINDER PORT
- P = PRESSURE PORT
- T = TANK PORT
- X = PILOT PORT
- Y = DRAIN PORT

1-1/2" NPTF BOTTOM PORTED

2" BOTTOM PORTED

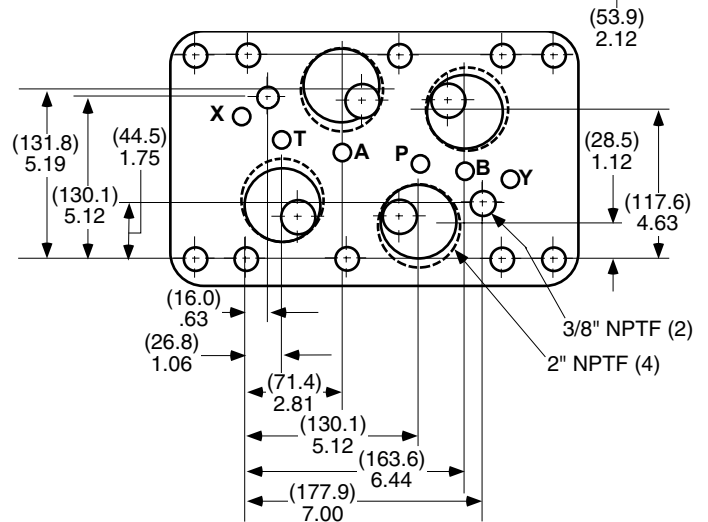
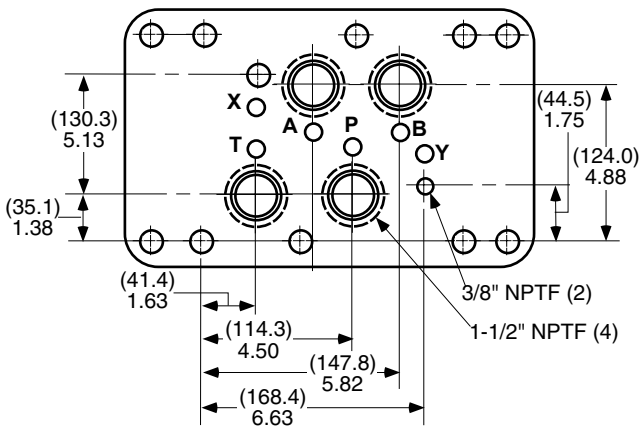
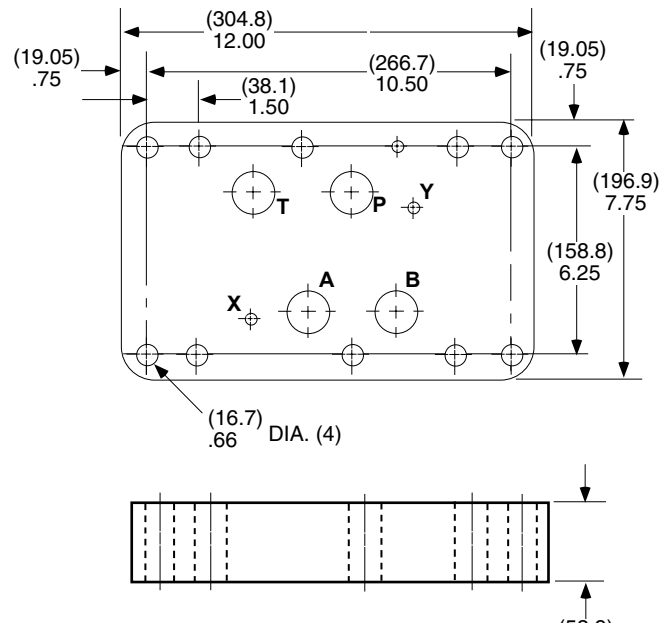
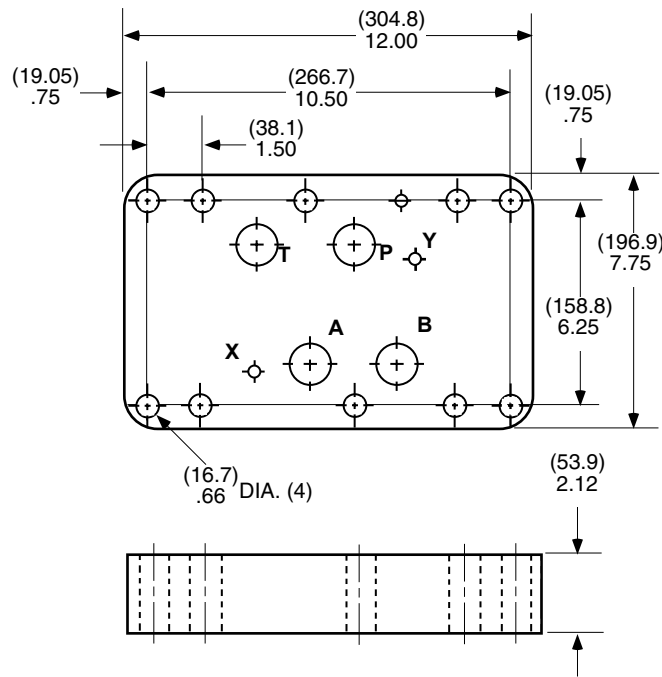

ORDERING INFORMATION

SELECT ONE
SD10 - C **- B**

CODE	PORT SIZE
150	1-1/2" NPTF
200	2" NPTF

WEIGHT: 46 lbs. (20.9 kg.) CAST IRON

NFPA 2F06

SUBPLATES



NFPA SIZE: 2F06 (FORMERLY 2F02)

NOTES: X= PILOT PORT
Y = DRAIN PORT

DIMENSIONS (MILLIMETERS)
INCHES

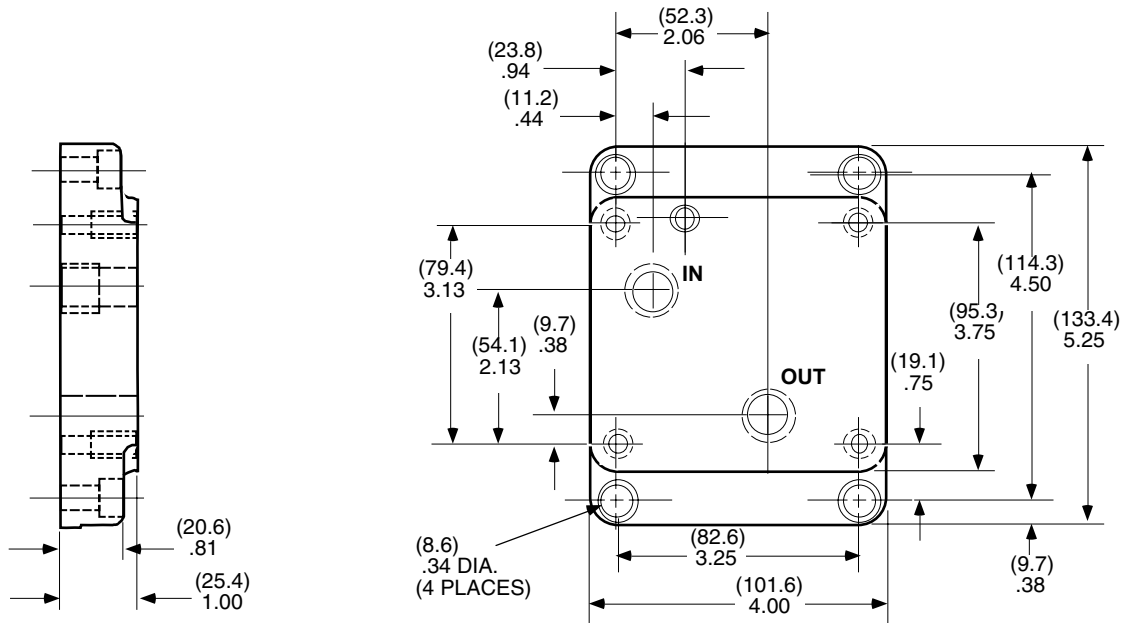

ORDERING INFORMATION

S2F06 – C50 – B

NOTE: 1/2" NPTF BOTTOM PORTED
WEIGHT: 5 lbs (2.3 kg) CAST IRON

COVER PLATES

3500 PSI PRESSURE RATED

COVER PLATE

USE TO BLANK STATION ON A MULTIPLE VALVE MANIFOLD

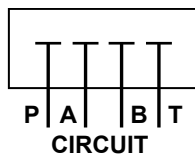

- KIT:
 (4) SOCKET HEAD CAP SCREWS
 (4) LOCKWASHERS
 (4) VITON O-RINGS

DIMENSIONS: (MILLIMETERS)
INCHES

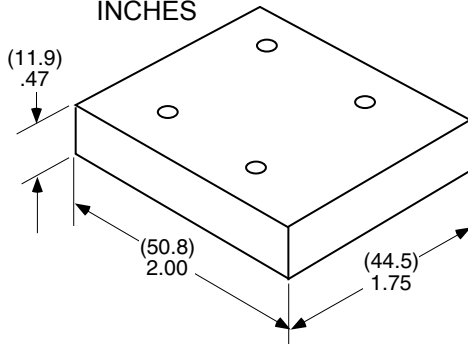

ORDERING CODE: MC03

WEIGHT: 0.5 lbs (0.23 kg.) ALUMINUM

COVER PLATE w/"P" GAUGE PORT

USE TO BLANK STATION ON A MULTIPLE VALVE MANIFOLD

DIMENSIONS: (MILLIMETERS)
INCHES

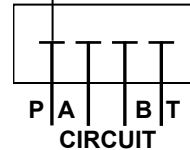
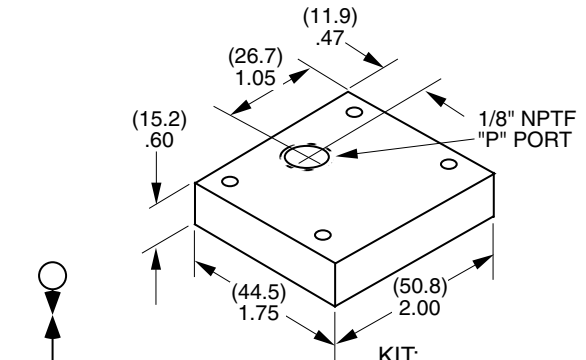

- KIT:
 (4) SOCKET HEAD CAP SCREWS
 (4) LOCKWASHERS
 (4) VITON O-RINGS
 (1) LOCATOR ROLL PIN

ORDERING CODE: MC03-G1

WEIGHT: 0.5 lbs (0.23 kg.) ALUMINUM

COVER PLATE w/CROSSOVER PORT CONNECTIONS

- KIT:
 (4) SOCKET HEAD CAP SCREWS
 (4) LOCKWASHERS
 (4) VITON O-RINGS
 (1) LOCATOR ROLL PIN

CIRCUIT MODEL "C1"

P → T, A & B BLOCKED

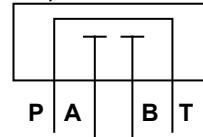

CIRCUIT MODEL "C2"

P → B, A → T

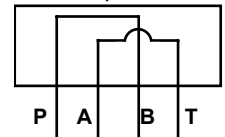

ORDERING INFORMATION

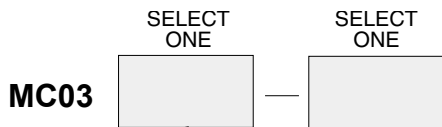

MATERIAL		CONFIGURATION	
CODE	DESCRIPTION	CODE	DESCRIPTION
OMIT	ALUMINUM	C1	P to T, A & B BLOCKED
S	STEEL	C2	P to B, A to T

NOTES:

- MODEL CODES MCO3-C1-G1, MCO3-C2-G1 NOT AVAILABLE.
 - STEEL OPTION AVAILABLE ONLY ON MODEL CODE MCO3-S-C1
- WEIGHTS: ALUMINUM - 0.5 lbs. (.23 kg.) STEEL-1.0 lbs (.45 kg.)

DIMENSIONS: (MILLIMETERS)
INCHES

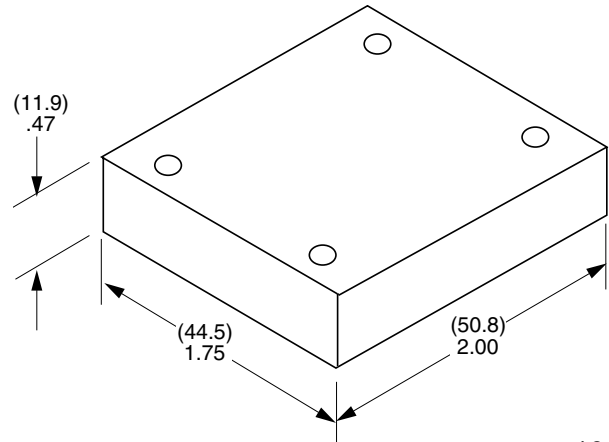

COVER PLATES



3500 PSI PRESSURE RATED

COVER PLATE NFPA D05 (FORMERLY D02)
USE TO BLANK STATION ON A MULTIPLE VALVE
MANIFOLD

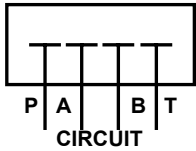

DIMENSIONS: (MILLIMETERS)
INCHES

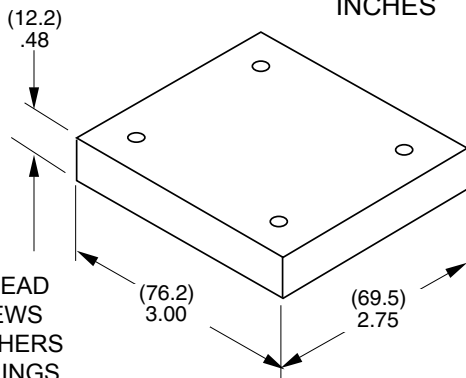

- KIT:**
(4) SOCKET HEAD
CAP SCREWS
(4) LOCKWASHERS
(5) VITON O-RINGS

ORDERING CODE: MC05

WEIGHT: 0.50 lbs (0.23 kg.) ALUMINUM

COVER PLATE w/"P" GAUGE PORT
USE TO BLANK STATION ON A MULTIPLE VALVE
MANIFOLD

- KIT:**
(4) SOCKET HEAD
CAP SCREWS
(4) LOCKWASHERS
(5) VITON O-RINGS

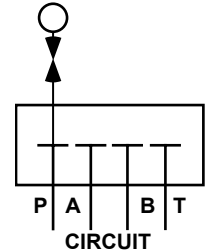

DIMENSIONS: (MILLIMETERS)
INCHES

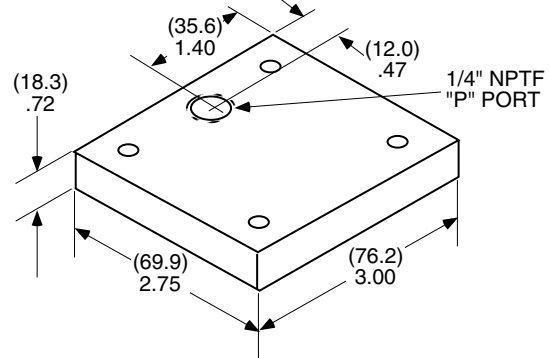

ORDERING CODE: MC05-G2

WEIGHT: 1.0 lbs (0.45 kg.) ALUMINUM

COVER PLATE w/CROSSOVER PORT CONNECTIONS

- KIT:**
(4) SOCKET HEAD CAP SCREWS
(4) LOCKWASHERS
(5) VITON O-RINGS

CIRCUIT MODEL "C1"

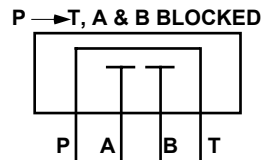

CIRCUIT MODEL "C2"

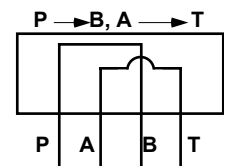

ORDERING INFORMATION

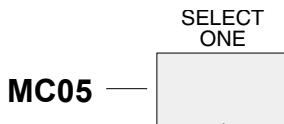

CONFIGURATION	
CODE	DESCRIPTION
C1	P to T, A & B BLOCKED
C2	P to B, A to T

NOTE:

- STEEL OPTION AVAILABLE ONLY ON COFIGURATION CODE "C1".
WEIGHTS: ALUMINUM - 0.5 lbs. (.23 kg); STEEL - 1.0 lbs (.45 kg.).

DIMENSIONS: (MILLIMETERS)
INCHES

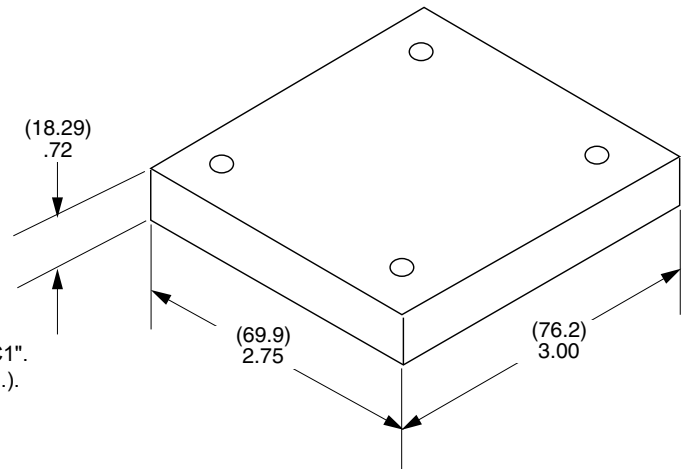

COVER PLATES

3500 PSI PRESSURE RATED

COVER PLATE NFPA D08 SIZE (FORMERLY D06)

BLANKING PLATE WITH "P" GAUGE PORT OPTION USED TO BLOCK STATION ON A MULTIPLE VALVE MANIFOLD.

DIMENSIONS: (MILLIMETERS)
 INCHES

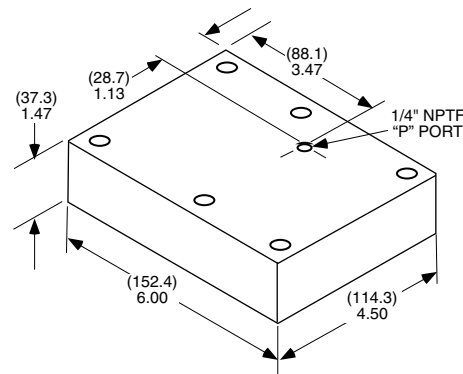

THE SERIES PLATE IS USED TO CONNECT P TO T PORTS ON A MULTIPLE VALVE MANIFOLD, BLOCKING A & B PORTS.. HAS OPTIONAL GAUGE PORT.

KIT:

- (6) SOCKET HEAD CAP SCREWS
- (6) LOCKWASHERS
- (6) VITON O-RINGS
- (2) LOCATOR ROLL PINS

CIRCUIT MODEL MC08

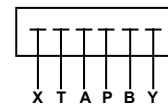

CIRCUIT MODEL MC08

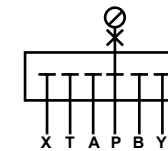

SERIES CIRCUIT MODEL MC08-C1

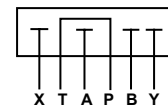

SERIES CIRCUIT MODEL MC08-C1-G2

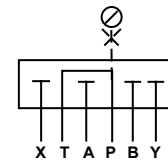

ORDERING INFORMATION

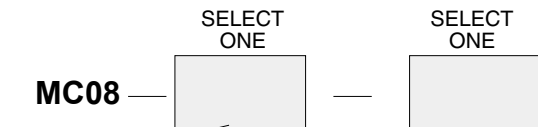

CONFIGURATION	
CODE	DESCRIPTION
OMIT	BLANK
C1	P to T, OTHER PORTS BLOCKED

CONFIGURATION	
CODE	DESCRIPTION
OMIT	BLANK
G2	W/GAUGE PORT

NOTE:

- 1. MODEL CODE MC08 PLATE THICKNESS IS (18.3) .72.

WEIGHT: 2.0 lbs.(.91 kg.) ALUMINUM

NFPA D05, D07

TRANSITION PLATES



3500 PSI PRESSURE RATED

TRANSITION PLATE

NFPA D05 SURFACE TO D07
(Formerly D02 to D04)

DIMENSIONS: (MILLIMETERS)
INCHES

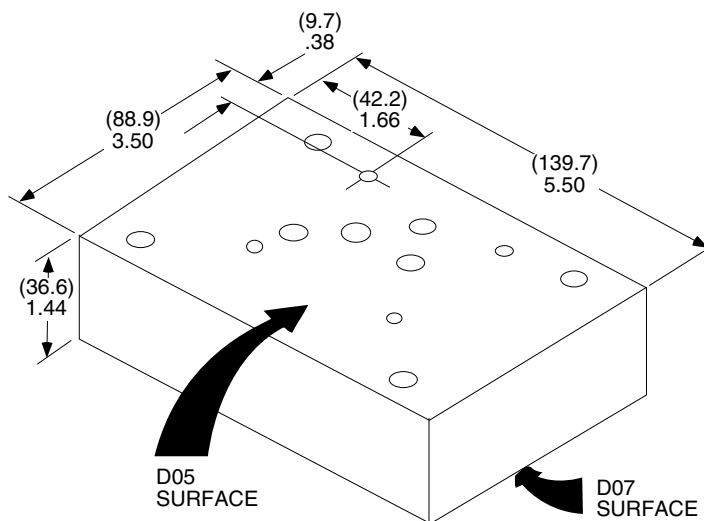

KIT:

- (6) SOCKET HEAD CAP SCREWS
- (6) LOCKWASHERS
- (6) VITON O-RINGS
- (2) LOCATOR ROLL PINS

FLOW PATHS:

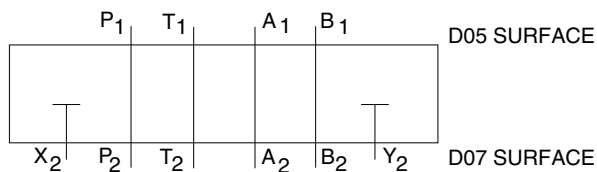

ORDER CODE: MA05 - 07

WEIGHT: 2.0 lbs.(.91 kg.) ALUMINUM

TRANSITION PLATES

3500 PSI PRESSURE RATED

TRANSITION PLATE

NFPA D05 TO D08 SURFACES
 (FORMERLY D02 TO D06)

DIMENSIONS: (MILLIMETERS)
 INCHES

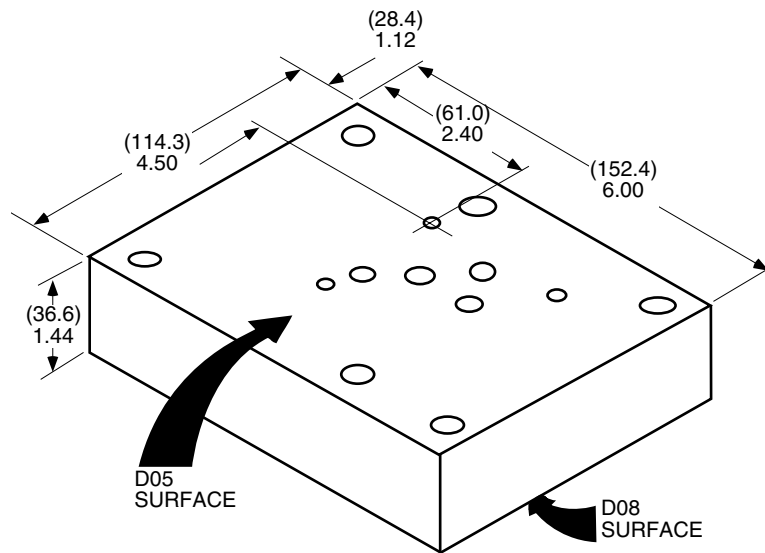

FLOW PATHS:

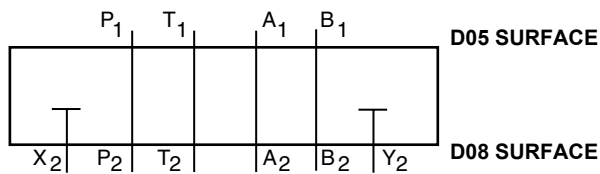

KIT:

- (6) SOCKET HEAD CAP SCREWS
- (6) LOCKWASHERS
- (6) VITON O-RINGS
- (2) LOCATOR ROLL PINS

ORDER CODE: MA05-08

WEIGHT: .7 lbs. (.3 kg.) ALUMINUM

NFPA D03, D05, D08, D10



TRANSITION PLATES

TRANSITION PLATE

NFPA D03 TO D05 SIZE
(FORMERLY D01 TO D02).

3500 PSI PRESSURE RATED

DIMENSIONS: (MILLIMETERS)
INCHES

FLOW PATHS

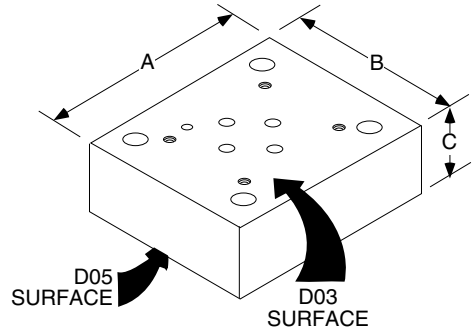
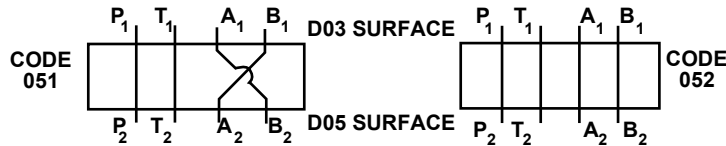

ORDERING INFORMATION

SELECT ONE

MA03

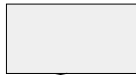

PORTS	
CODE	DESCRIPTION
051	P ₁ to P ₂ , T ₁ to T ₂ A ₁ to B ₂ , B ₁ to A ₂
052	P ₁ to P ₂ , T ₁ to T ₂ A ₁ to A ₂ , B ₁ to B ₂

CODE	A	B	C
051	(76.2) 3.00	(69.9) 2.75	(25.4) 1.00
052	(69.0) 2.75	(63.5) 2.50	(37.1) 1.46

KIT:

- (4) SOCKET HEAD CAP SCREWS
- (4) LOCKWASHERS
- (5) VITON O-RINGS

WEIGHT: .7 lbs. (.3 kg.) ALUMINUM

TRANSITION PLATE

NFPA D08 TO D10 SIZE
(FORMERLY D06 TO D10)

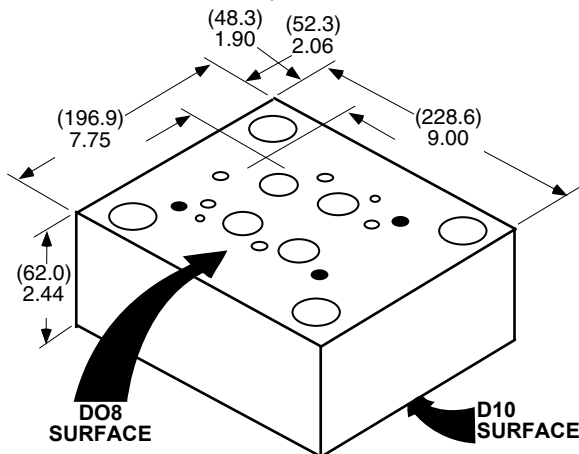

FLOW PATHS

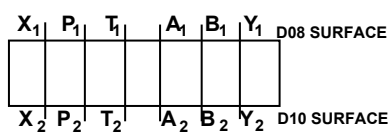

KIT:

- (6) SOCKET HEAD CAP SCREWS
- (6) LOCKWASHERS
- (6) VITON O-RINGS
- (2) LOCATOR ROLL PINS

ORDER CODE: MA08-10

WEIGHT: 14 lbs. (6.35 kg.) ALUMINUM

TRANSITION PLATE

NFPA D03 TO D08 SIZE
(FORMERLY D01 TO D06)

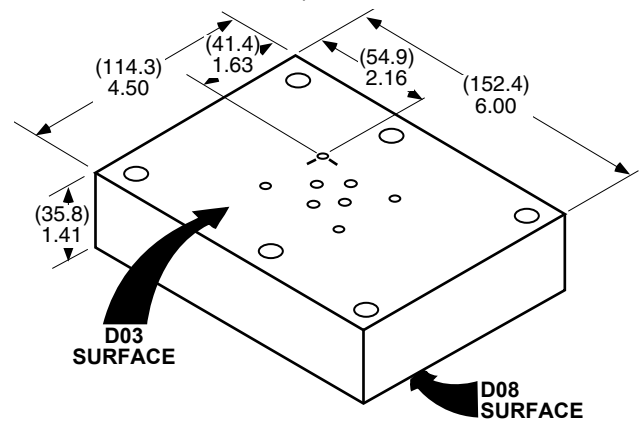

FLOW PATHS

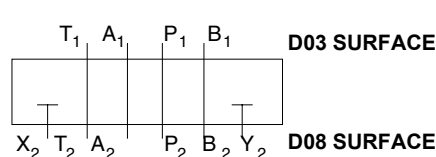

KIT:

- (6) SOCKET HEAD CAP SCREWS
- (6) LOCKWASHERS
- (6) VITON O-RINGS
- (2) LOCATOR ROLL PINS

ORDER CODE: MA03 - 08

WEIGHT: 2.0 lbs. (.91 kg.) ALUMINUM

TAPPING PLATES

TAPPING PLATES

3500 PSI PRESSURE RATED

NFPA D03 OR D05 SIZE (FORMERLY D01 OR D02).
 USED FOR AUXILIARY PORT CONNECTIONS.

DIMENSIONS: (MILLIMETERS)
 INCHES

NOTE: D03 MOUNTING SHOWN FOR REFERENCE

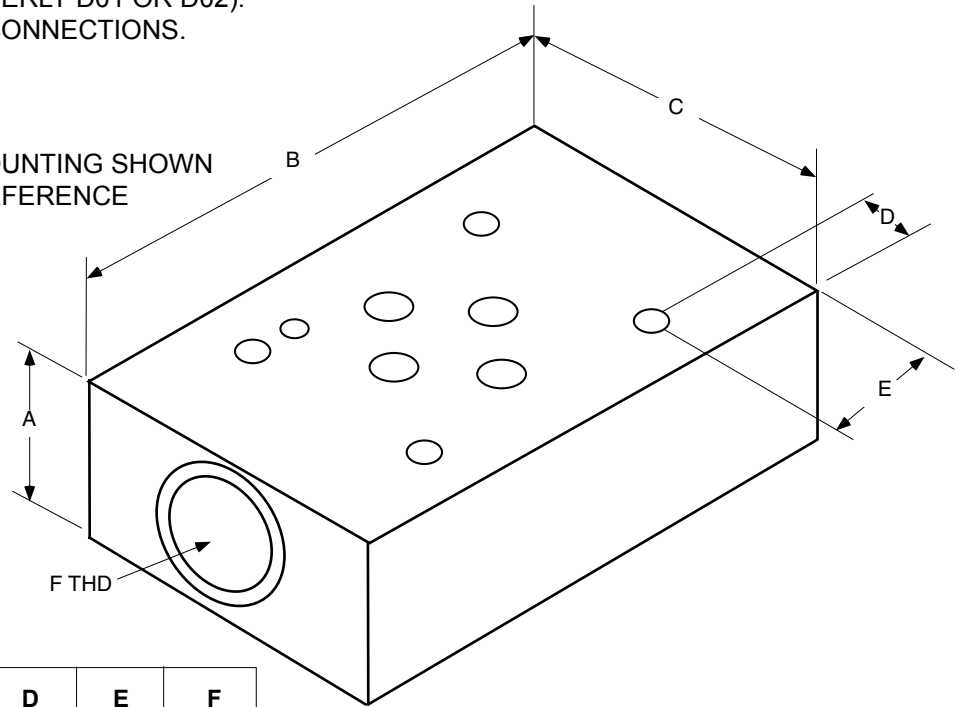

DIMENSIONS

CODE	A	B	C	D	E	F
3	(24.4) .96	(81.1) 3.19	(50.8) 2.00	(9.5) .38	(21.3) .84	?
5	(49.3) 1.94	(101.6) 4.00	(76.2) 3.00	(15.2) .60	(23.8) .94	?

? #6 SAE OR 1/4" NPTF

KIT:

- (1) TAPPING PLATE, ALUMINUM
- (4 OR 5) VITON O-RINGS (D03 OR D05 SIZE)
- (1) LOCATOR ROLL PIN (D03 SIZE)

FLOW PATHS

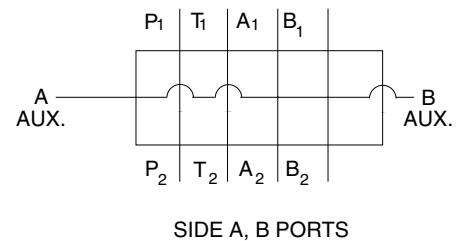
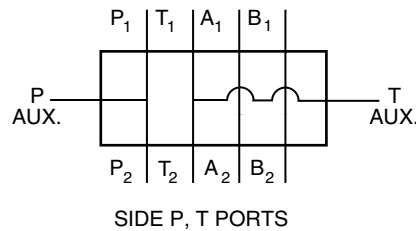
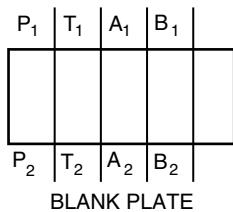

ORDERING INFORMATION

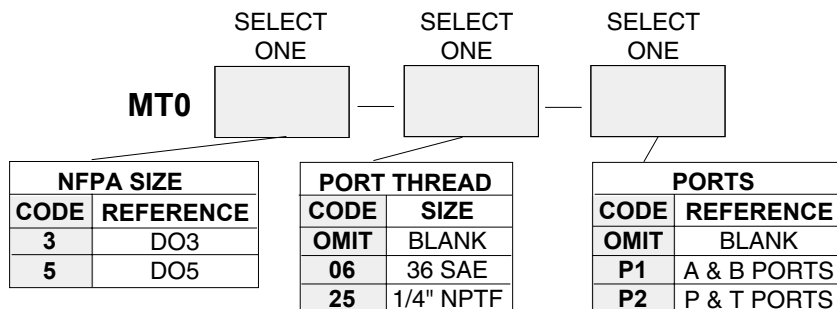

MANIFOLD ACCESSORIES

DIMENSIONS: (MILLIMETERS)
INCHES

MANIFOLD PLUG ASSEMBLY

USE TO ISOLATE STATIONS ON A MULTIPLE VALVE MANIFOLD.

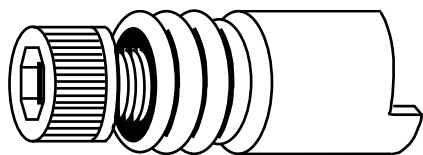

KIT:
(1) BODY PLUG ASSEMBLY

NOTES:

1. D03 SIZE PLUG USE 5/16" HEX WRENCH
2. D05 SIZE PLUG USE 3/8" HEX WRENCH

ORDERING INFORMATION

SELECT ONE

PDO

CODE	NFPA SIZE MANIFOLD	WEIGHT lbs. (kg.)
3	D03	0.10 (0.05)
5	D05	0.25 (0.11)

NOTES: A = A CYLINDER PORT
P = PRESSURE PORT
X = PILOT PORT

B = B CYLINDER PORT
T = TANK PORT
Y = DRAIN PORT

MOUNTING FLANGE

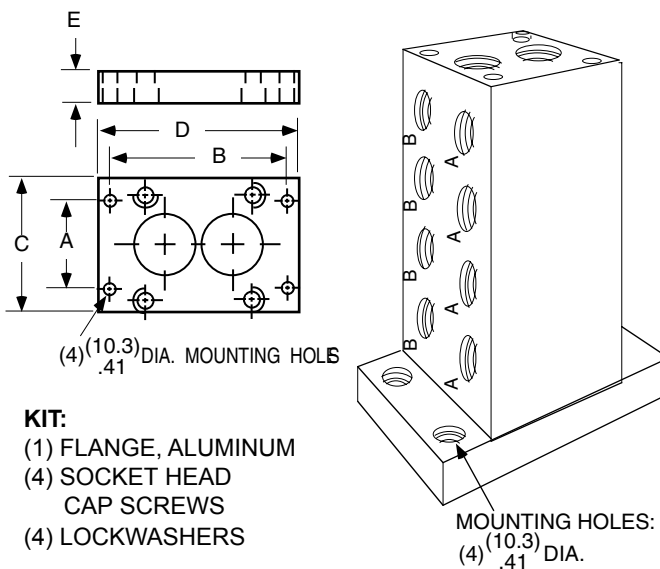

KIT:

- (1) FLANGE, ALUMINUM
- (4) SOCKET HEAD CAP SCREWS
- (4) LOCKWASHERS

ORDERING INFORMATION

SELECT ONE

MF0

CODE	NFPA SIZE	A	B	C	D	E
3	D03	(57.2)	(114.3)	(76.2)	(130.3)	(16.0)
		2.25	4.50	3.00	5.13	.63
5	D05	(57.2)	(114.3)	(89.0)	(130.3)	(19.1)
		2.25	4.50	3.50	5.13	.75

WEIGHT: 2.0 lbs. (.91 kg.)

STEEL FOOT BRACKETS

USE TO MOUNT MULTIPLE VALVE MANIFOLD.

ORDERING INFORMATION

SELECT ONE

FD0

CODE	NFPA SIZE	DIMENSIONS / WEIGHT						lbs./(kg.)
		A	B	C	D	E	F	
3	D03	(76.2)	(8.1)	(12.7)	(60.5)	(38.1)	(25.4)	0.5(0.22)
		3.00	.32	.50	2.38	1.50	1.00	
5	D05	(89.0)	(12.7)	(12.7)	(69.9)	(38.1)	(38.1)	0.8 (0.35)
		3.50	.50	.50	2.75	1.50	1.50	
8	D08	(152.4)	(15.0)	(12.7)	(123.9)	(38.1)	(38.1)	2.0 (0.88)
		6.00	.59	.50	4.88	1.50	1.50	

NOTE: D03 - STEEL, D05 & D08 - ALUMINUM

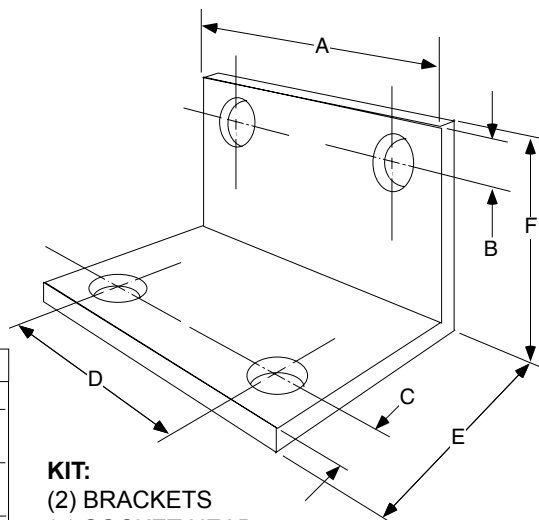

KIT:

- (2) BRACKETS
- (4) SOCKET HEAD CAP SCREWS
- (4) LOCKWASHERS

VALVE BOLT KITS

DIRECTIONAL VALVE	VALVE STACK	ORDER CODE	TYPE	LENGTH	WEIGHT lbs. (kg)
V5M NFPA D03 KIT: (4) 10-24NC FASTENERS (4) #10 LOCKWASHERS	DIRECTIONAL VALVE	BD03-100	BOLT	(25.5) 1.00	0.05 (0.02)
	VALVE + (1)(40.0) POLYSTAC	BD03-250	BOLT	(63.8) 2.50	0.08 (0.04)
	VALVE + (2)(40.0) POLYSTAC	BD03-4125	BOLT	(104.8) 4.125	0.18 (0.08)
	VALVE + (3)(40.0) POLYSTAC	BD03-575	BOLT	(146.0) 5.75	0.23 (0.10)
	VALVE+ (2)(40.0) POLYSTAC	BD03-460	STUD	(117.3) 4.60	0.18 (0.08)
	VALVE + (3)(40.0) POLYSTAC	BD03-616	STUD	(157.1) 6.16	0.23 (0.10)
V12M NFPA D05 KIT: (4) 1/4-20NC FASTENERS (4) 1/4" LOCKWASHERS	DIRECTIONAL VALVE	BD05-175	BOLT	(44.6) 1.75	0.11 (0.05)
	VALVE + (1)(55.0) POLYSTAC	BD05-400	BOLT	(102.0) 4.00	0.24 (0.10)
	VALVE + (2)(55.0) POLYSTAC	BD05-6125	BOLT	(155.6) 6.125	0.44 (0.20)
	VALVE + (3)(55.0) POLYSTAC	BD05-825	BOLT	(209.6) 8.25	0.55 (0.25)
	VALVE + (2)(55.0) POLYSTAC	BD05-667	STUD	(170.1) 6.67	0.44 (0.20)
	VALVE + (3)(55.0) POLYSTAC	BD05-884	STUD	(225.4) 8.84	0.55 (0.25)
V50M DVS50M NFPA D08 (6) 1/2-13NC FASTENERS (6) 1/2" LOCKWASHERS	DVS50M -- DEACCELATROL	BD08-275	BOLT	(70.1) 2.75	1.25 (0.57)
	DIRECTIONAL VALVE	BD08-275	BOLT	(70.1) 2.75	1.25 (0.57)
	VALVE + (1)(88.9) POLYSTAC	BD08-625	BOLT	(159.4) 6.25	2.25 (1.02)
	VALVE + (1)(101.6) POLYSTAC	BD08-675	BOLT	(172.1) 6.75	2.40 (1.08)
	VALVE + (2)(88.9) POLYSTAC	BD08-9625	BOLT	(244.5) 9.625	3.75 (1.70)
	VALVE + (1)(88.9) + (1)(101.6) POLYSTAC	BD08-1020	BOLT	(260.0) 10.25	4.00 (1.81)
	VALVE + (2)(101.6) POLYSTAC	BD08-1080	BOLT	(273.0) 10.75	4.13 (1.87)
	VALVE + (2)(88.9) POLYSTAC	BD08-1025	STUD	(261.4) 10.25	3.75 (1.70)
	VALVE + (1)(88.9) + (1)(101.6) POLYSTAC	BD08-1075	STUD	(274.1) 10.75	4.00 (1.81)
	VALVE + (2)(101.6) POLYSTAC	BD08-1125	STUD	(286.9) 11.25	4.13 (1.87)
V100M NFPA D10 KIT: (6) 3/4-10NC FASTENERS (6) 3/4" LOCKWASHERS	DIRECTIONAL VALVE	BD10-250	BOLT	(63.8) 2.50	2.63 (1.19)
VALVE					
F12M NFPA 2F06 KIT: (4) 5/16"-18NC FASTENERS (4) 5/16" LOCKWASHERS	FLOW CONTROL	B2F06-225	BOLT	(57.8) 2.25	0.25 (0.11)

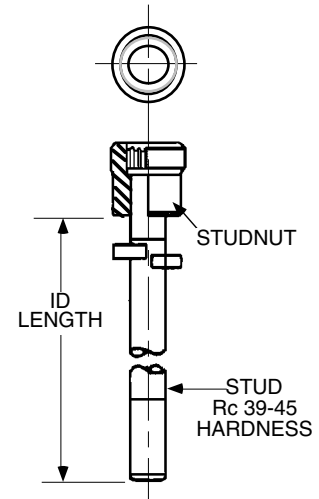
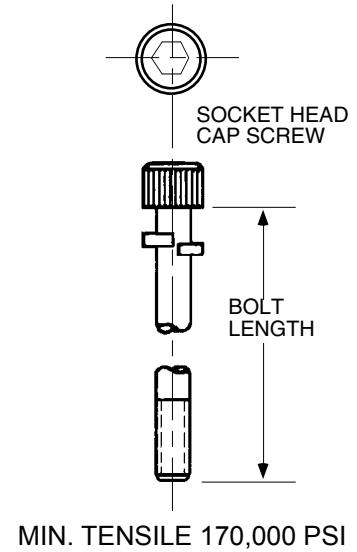

STACKING EXAMPLE

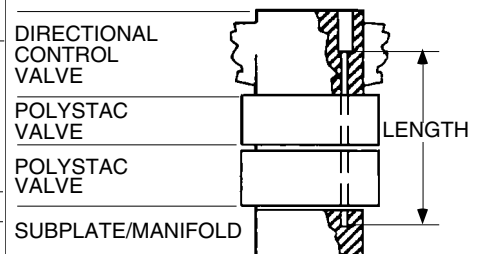

T = TANK PORT
 X = PILOT PORT
 Y = DRAIN PORT

NFPA D03, D05

MOUNTING SURFACES

Mounting surface must be flat within .01 mm per 100 mm (.0004 in. per 4.0 in.) and N8 (63AA) finish.

NOTES: A = A CYLINDER PORT
 B = B CYLINDER PORT
 P = PRESSURE PORT

D03 MOUNTING SURFACE (Formerly D01)
 CONFORMS TO NFPA/T3.5.1M R1-1984, ANSI/B93.7M-1986, ISO 4401 SIZE 03

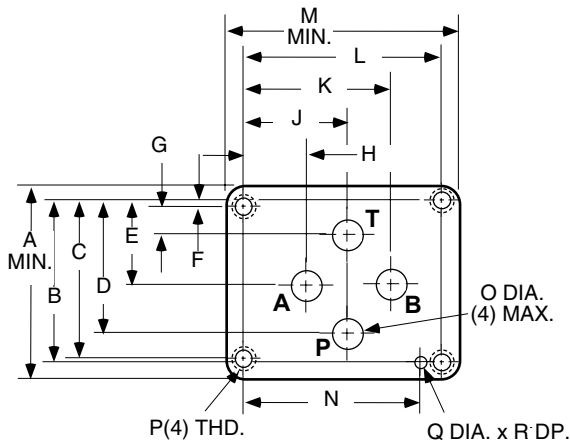

DIMENSIONS

A	B	C	D	E	F	G	H	J
(43.0)	(31.8)	(31.0)	(25.9)	(15.5)	(5.1)	(0.8)	(12.7)	(21.5)
1.70	1.25	1.22	1.02	0.61	0.20	0.03	0.50	0.85

K	L	M	N	O	P	Q	R
(30.2)	(40.5)	(51.0)	(33.0)	(6.3)	10-24 UNC-2B	(4.0)	(4.0)
1.19	1.59	2.00	1.30	0.25		0.16	0.16

D05 MOUNTING SURFACE (Formerly D02)
 CONFORMS TO NFPA/T3.5.1M R1-1984, ANSI/B93.7M-1986, ISO 4401 SIZE 05

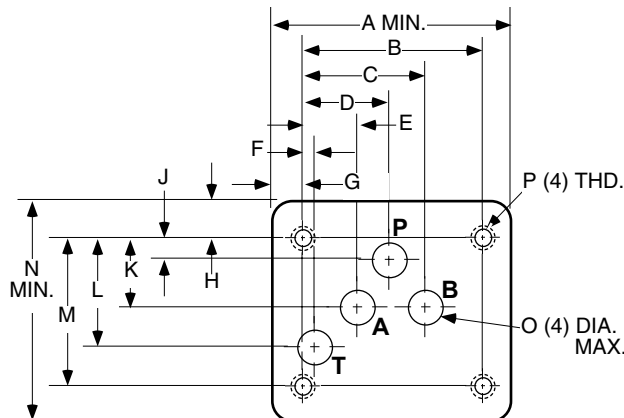

DIMENSIONS

A	B	C	D	E	F	G	H	J
(72.1)	(54.0)	(37.3)	(27.0)	(16.7)	(3.2)	(9.1)	(11.2)	(6.4)
2.84	2.13	1.47	1.06	0.66	0.13	0.36	0.44	0.25

K	L	M	N	O	P
(21.4)	(32.5)	(46.0)	(57.9)	(11.2)	1/4-20 UNC
0.84	1.28	1.81	2.28	0.44	

MOUNTING SURFACES

Mounting surface must be flat within .01 mm per 100 mm (.0004 in. per 4.0 in.) and N8 (63AA) finish.

NOTES: A = A CYLINDER PORT T = TANK PORT
 B = B CYLINDER PORT X = PILOT PORT
 P = PRESSURE PORT Y = DRAIN PORT

D08 MOUNTING SURFACE

CONFORMS TO NFPA/T3.5.1M R1-1984, ANSI/B93.7M-1986, ISO 4401 SIZE 08

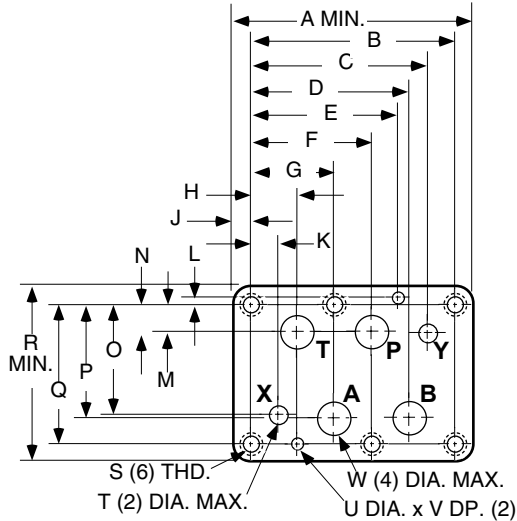

DIMENSIONS

A	B	C	D	E	F	G	H	J	K
(152.4)	(130.2)	(112.7)	(100.8)	(94.5)	(77.0)	(53.2)	(29.4)	(11.1)	(17.5)
6.00	5.13	4.44	3.97	3.77	3.03	2.09	1.16	0.44	0.69

L	M	N	O	P	Q	R	T	U	V	W
(4.8)	(17.5)	(19.0)	(73.0)	(74.6)	(92.1)	(116.0)	(11.2)	(7.5)	(9.7)	(23.4)
0.19	0.69	0.75	2.88	2.93	3.63	4.57	0.44	0.28	0.38	0.92

S: 1/2-13 UNC

D10 MOUNTING SURFACE

CONFORMS TO NFPA/T3.5.1M R1-1984, ANSI/B93.7M-1986, ISO 4401 SIZE 10

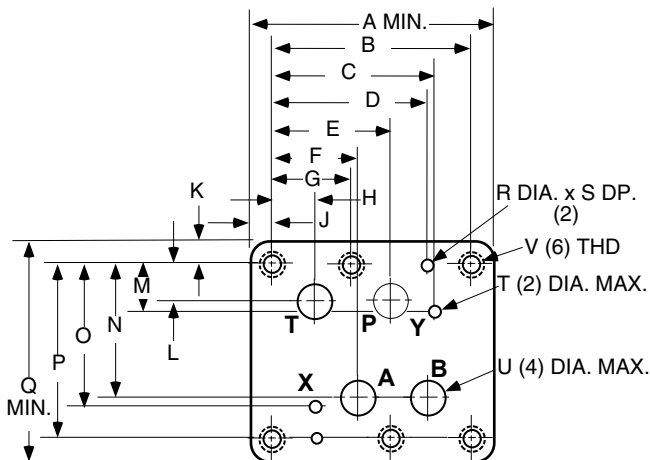

DIMENSIONS

A	B	C	D	E	F	G	H	J	K
(230.1)	(190.5)	(168.4)	(147.6)	(114.3)	(82.6)	(76.2)	(41.4)	(19.0)	(19.0)
9.06	7.50	6.63	5.81	4.50	3.25	3.00	1.63	.75	.75

L	M	N	O	P	Q	R	S	T	U
(35.1)	(44.5)	(124.0)	(130.3)	(158.8)	(198.9)	(7.1)	(9.7)	(11.2)	(31.8)
1.38	1.75	4.88	5.13	6.25	7.83	.28	.38	.44	1.25

V: 3/4-10 UNC

NFPA 2F06 & P08

MOUNTING SURFACES

Mounting surface must be flat within .01 mm per 100 mm (.0004 in. per 4.0 in.) and N8 (63AA) finish.

NOTES:: X = PILOT PORT
 Y = DRAIN PORT

2F06 MOUNTING SURFACE (FORMERLY 2F02)

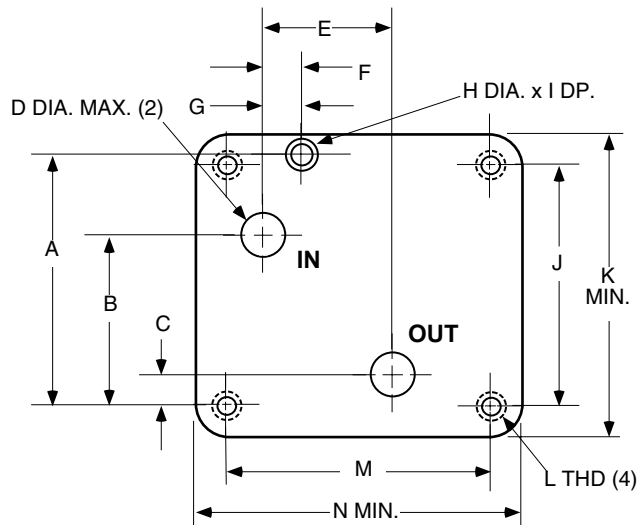

DIMENSIONS

DIM.	MM	IN.
A	79.4	3.13
B	54.1	2.13
C	9.7	.38
D	14.3	.56
E	52.3	2.06
F	23.8	.94
G	11.2	.44
H	7.1	.28
I	9.5	.38
J	76.2	3.00
K	95.3	3.75
L	5/16-18 UNC	
M	82.6	3.25
N	101.6	4.00

P08 MOUNTING SURFACE (FORMERLY P06)

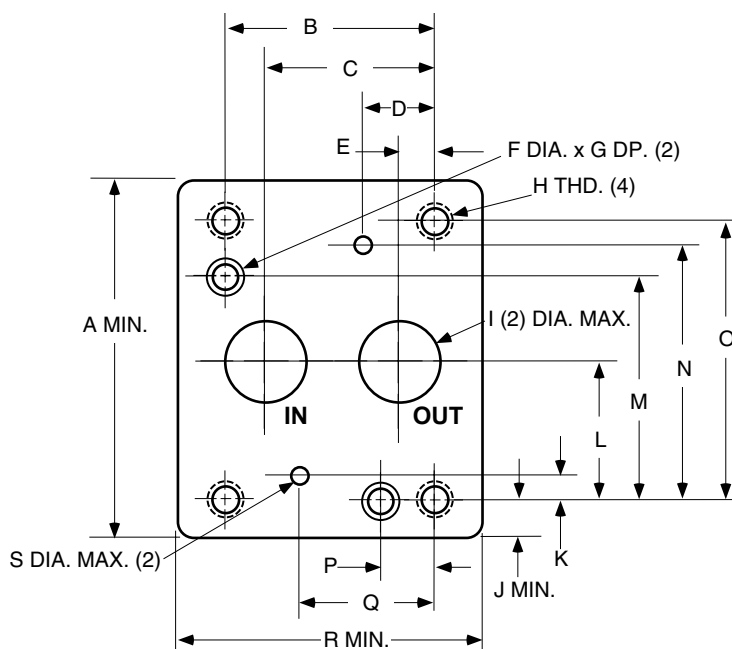

DIMENSIONS

DIM.	MM	IN.
A	97.0	3.81
B	60.4	2.38
C	49.0	1.94
D	21.0	.81
E	11.0	.44
F	7.1	.28
G	9.7	.38
H	3/8-16 UNC	
I	22.4	.88
J	11.0	.44
K	6.4	.25
L	40.0	1.56
M	64.0	2.50
N	73.0	2.88
O	80.0	3.13
P	16.0	.63
Q	40.0	1.56
R	78.0	3.06
S	4.8	.19